

# REGENERATIVE AIRPORT SWEEPER

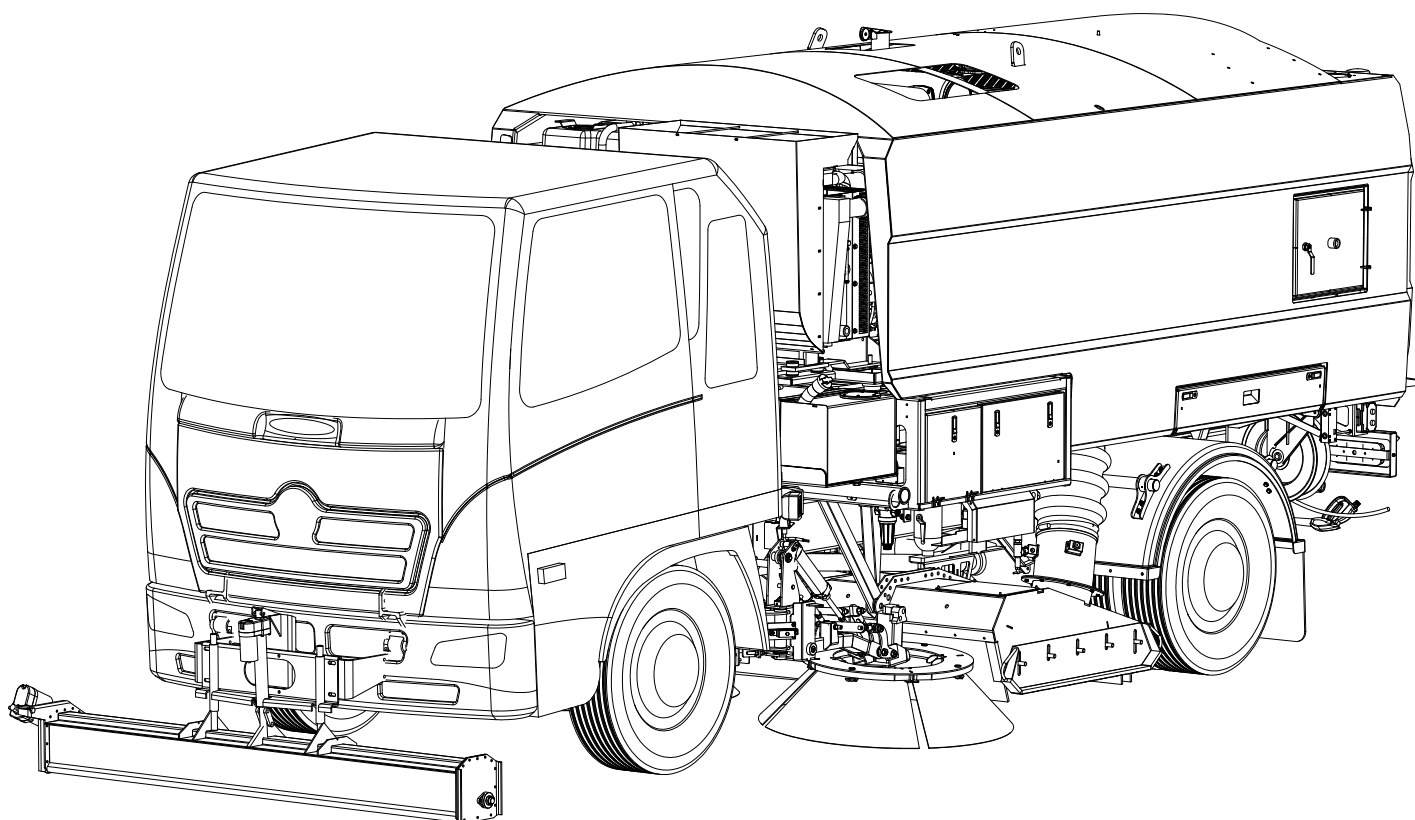

**ROOTS -  
Perfect from  
Product  
to Service**

# REGENERATIVE AIRPORT SWEEPER

## Technical Specification

### Auxiliary Engine

Manufacturer	: Cummins
Model	: QSB 4.5
Displacement	: 4500 cc
Horsepower	: 128hp@2000RPM
Net Toque	: 546Nm@1400RPM
Air Cleaner	: Dual Element with Restriction Indicator
Oil Filter	: Spin On, Full Flow
Safety shutdown	: Cooking water temperature and Engine Oil Pressure

### Blower Fan

Type	: Centrifugal
Construction	: High Tensile Structural
Bearings	: 2 Sealer Bearings
shaft	: 50mm Diameter
Housing	: Modular with Replaceable Liner
Drive	: 5-V Belt
Certification	: 20,000 CFM by Fan Flow Calculation

### Sweeper Body

Hopper	: Heavy Gauge AISI 304 Stainless Steel
Steel	: 3mm (11 gauge) for Walls and Floor
Construction	: Welded Stainless Steel
Volumetric Capacity	: 6 cubic meters (7.8 Cubic Yards)
Usable Capacity	: 5.6 cubic meters
Dumping Methods	: Rear Door Dump
Dump Angle	: 52 deg
Dump Door	: 1800mm Self Locking Hyd Fingers
Dump Height	: 1100mm
Hopper Screen	: 18,280 sq.cm (2800 sq inches)
Inspection Doors	: One each side of Hopper

### Sweeper Head

Type	: Broom in head with down pressure
Air Blast	: Integral to head on left side
Function	: Dual Chamber Full Width Blast Orifice
Dimensions	: 2400mm * 1160mm
Head Area	: 30,300 sq cm (3140 Square Inches)
Broom Size	: 300mm * 1650mm (polypropylene)
Blast Orifice	: High Speed located in Head
Suspension	: Adjustable spring with drag link
Suction Hose	: 250mm Diameter
Pressure Hose	: 350mm Diameter
Pressure Bleeder	: Electric Acatur Controlled
Safety Position	: Sweep Head & Side Broom during reverse
Raise & Lower	: Hydraulic Cylinder

### Gutter Brooms

Type	: Trailing Arm Design
Drive	: Hydraulic drive variable speed
Adjustment	: Adjustable for Down variable speed
Lifting	: Hydraulic
Down pressure	: Pneumatic
Flexibility	: All Direction
Diameter/Material	: 1000 mm, Steel or PP
Tilt Adjustment	: Electric-in-cab

### Hydraulic System

Drive	: Gear-pump
Pump Type	: Dual Output/Fixed Displacement
Reservoir	: 70 Litres (18.5 Gallons)
Filtration	: 10micron Spin-on
Pressure	: 150kg/sq cm (2176PSI)

### Dual Control

Pump	: Two Diaphragm Pump
Capacity	: 1000 Litres (264 Gallons)
Filter	: 80 mesh
Low water Shut Off	: Indication and buzzer in cab
Spray Bar	: Under the Chassis

### Spray Nozzles

Pick Up Head	: 4 Inside
Gutter Brooms	: 2 Each
Hopper	: 5 on screen
Hopper Inlet	: 2 orifices in Transition Opening
Suction Hose	: Inside

### Controls

Gauges	: In Cab
Shutdown System	: 2 point System (LLOP, Coolant temp)

### Steering

Steering	: Single
----------	----------

### Sweeping Width

Pick Up Head Only	: 2250 mm(88.5")
With 1 Gutter Broom	: 2775 mm(109")
With 2 Gutter Brooms	: 3600(141.5)

### Instrumentation

Sweeper Engine	: Techometer, Hourmeter, Voltmeter, Temperature gauge, Oil pressure Gauge
----------------	---

Overall Dimensions : Height : 3090mm • Width : 2400mm • Empty Weight : 8165 Kgs(18,000lbs) • Length : 6780mm.

Note:Overall Dimension will be very according to the Truck Models.

Options : CCTV Cameras (Rear,Left & Right), Reverse Beep, Rear Directional Arrow Bars, Wander hose dia 200mm, Length 3000mm, High Pressure gun and hose, Magnet bar length 2000mm, Beacon light.

Roots reserves the right to make any changes considered necessary for the purposes of improvement at any time or for any reason without prior notice, in line with its policy of continuous product development and progress.

**Our Product Range** - Sweepers, Scrubber-Driers, Vacuum Cleaners, Single Disc Scrubbers, Mini Floor Washers, High Pressure Water Jet Cleaners, City Sweepers, Bins, Mops & Trolleys.



### Roots Multiclean Ltd

R K G Industrial Estate, Ganapathy, Coimbatore - 641 006. India.  
Tel : +91 422 4330330. Fax : +91 422 2332107. Email : rmclsales@rootsemail.com  
Website : rootsmulticlean.in

